



because it works



INTERNAL AND EXTERNAL PIPE COATING

WWW.WIWA.COM

INTERNAL PIPE COATING



AUTOMATIC GUNS AND ROTARY ATOMIZERS FOR MANUAL AND AUTOMATIC LANCES

Pipes with a diameter of 50-800 mm can be coated internally without turning the pipe using a rotary atomizer. The coating is applied while drawing the movable lance backwards out of the pipe. Pipes with a diameter of 50-100 mm require a rotary atomizer with two centering guides for the corresponding pipe diameter. For pipes with a diameter of 100-400 mm (optionally up to 800 mm), we offer a continuously adjustable centering guide. A complete rotary atomizer unit includes a regulator unit with automatic gun and all fluid and air hoses necessary for mounting it on the pump. Based on this equipment, we also offer a handheld unit for manual internal coating of pipes, bends, and elbows up to 3 mtr. long. The size and form of the rotary atomizer depend on the pipe diameter and the material to be applied

USES

- Internal pipe coating with automatic guns for manual or automatic spray lances
- Internal coating of in-situ pipes with robotic technology and rotary atomizer
- Rotary atomizer systems for pipes larger than 50 mm diameter
- Coating of elbows and junctions with a rotary atomizer on a hand lance
- Special spray equipment for the coating of joints on cast iron pipe (diameter: 80 – 800 mm)

Note:

On request, we offer separate solutions for the external coating of pipes and the internal coating of pipes with larger diameters.

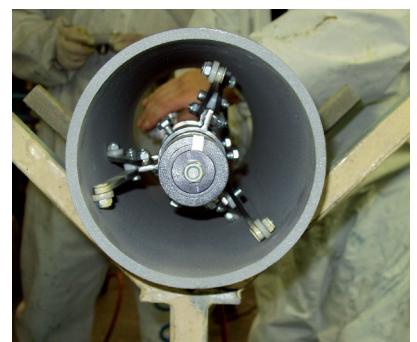

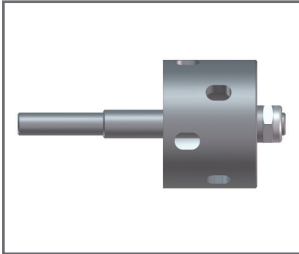

Rotary atomizer wheel
 ø 33 mm Order No.0656957
 ø 45 mm Order No. 0656958
 ø 90 mm Order No. 0656959

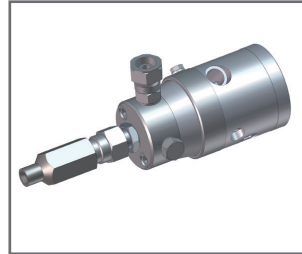

Automatic valve for
 internal pipe coating
 Order No. 0655976

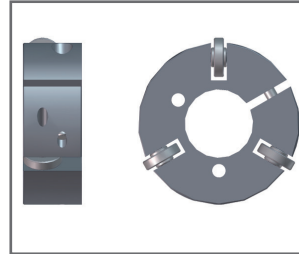

Centering guide with rollers
 69-78,5 mm Order No.0657948*
 77,5-97 mm Order No. 0657949*

*(2pcs.)



ø 50 mm Order No. 0658050*
 ø 60 mm Order No. 0658051*
 ø 65 mm Order No. 0658052*

*(2pcs.)

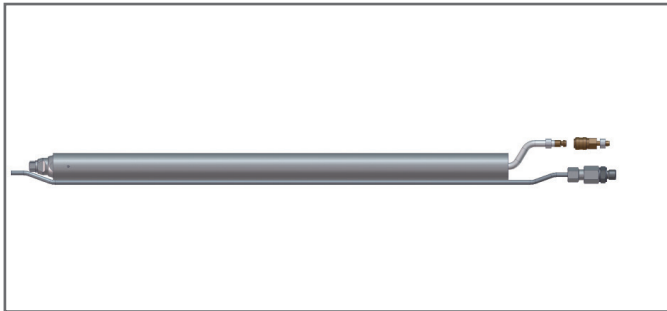

Lance with motor 600 mm long
 Order No. 0656960

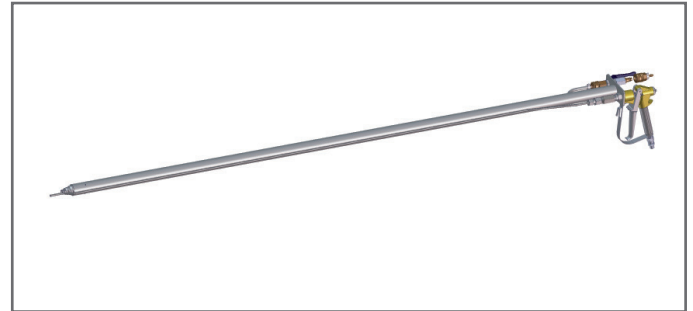

Hand lance with gun 1800 mm long
 Order No. 0656948

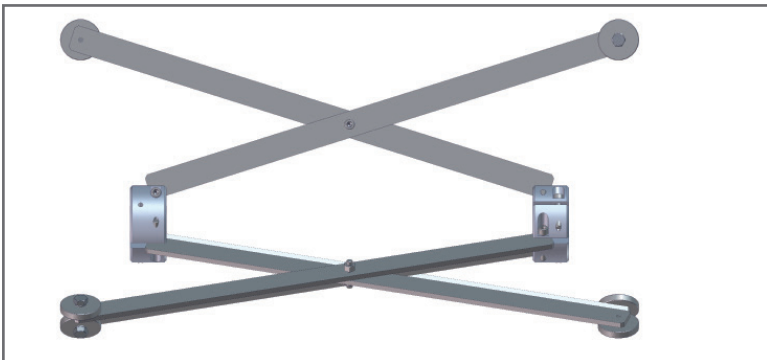

1. Guide ø 100 - ø 400 mm for lance
 Order No. 0656954

2. Guide ø 400 - ø 800 mm for lance
 Order No. 0656956

Conversion kit ø 400 - ø 800 mm (from Pos. 1 to Pos. 2)
 Order No. 0649924

Guide ø 100 - ø 400 mm for hand lance
 Order No. 0656949

Air and fluid hoses on request



Regulator unit for internal pipe coating
 Order No. 0655044

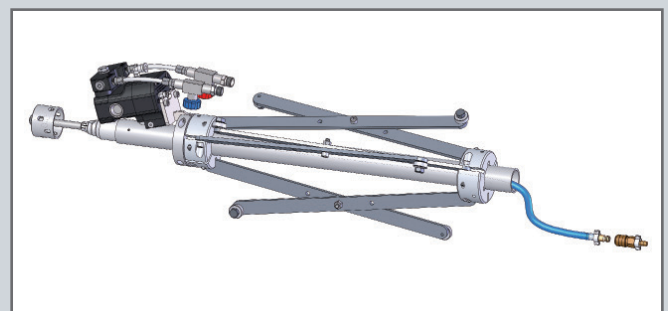

PU 4040 Automatic Gun for internal pipe coating with Polyurea
 Orde No. 0659289 • Guide ø 210- ø 400 mm
 (Larger dia. upon request)



because it works

PRODUCT RANGE EXAMPLES



Headquarters and Production

WIWA Wilhelm Wagner GmbH & Co. KG

35633 Lahnau, Germany
Phone: +49 (0) 6441 609-0

www.wiwa.de

WIWA Subsidiary USA

WIWA LLC – USA, Canada, Latin America
107 N. Main St.

P.O. Box 398, Alger, OH 45812
Tel.: +1-419-757-0141
Fax: +1-419-549-5173
Toll-Free: +1-855-757-0141

www.wiwausa.com

WIWA (Taicang) Co., Ltd.

Taicang City
Jiangsu Province 215400, P.R.China
Phone: +86-512-53548857

www.wiwa-china.com

WIWA Middle East General Trading LLC

Jebel Ali Industrial 1
DUBAI, United Arab Emirates
Phone: +9714-884-8220

www.wiwa-middleeast.com



WIWA FLEXIMIX Electronic 2K
Paint Spraying and Coating Equipment



WIWA Fluid Transfer Pumps
for diverse applications



WIWA DUOMIX Plural Component
Airless Paint Spraying Equipment



WIWA Airless, Air-Combi
and Hot Spraying Systems



WIWA POWERPACK XXL 2K
Hydraulic Systems



WIWA PU 460
Polyurea Systems

www.wiwa.com